

INSTRUCTION MANUAL

FOR



RUGER®

MODEL 44 CARBINE

This manual applies only to Carbines with serial numbers beginning with "102-", "103-" or "200-"



**NOTE: This model out of production.
— For reference use only.**

READ THE INSTRUCTIONS AND WARNINGS IN THIS MANUAL CAREFULLY BEFORE USING THIS FIREARM

THIS INSTRUCTION MANUAL SHOULD ALWAYS ACCOMPANY THIS FIREARM AND BE TRANSFERRED WITH IT UPON CHANGE OF OWNERSHIP, OR WHEN THE FIREARM IS LOANED OR PRESENTED TO ANOTHER PERSON.

A COPY OF THE INSTRUCTION MANUAL FOR EACH MODEL RUGER FIREARM IS AVAILABLE FROM THE FACTORY ON REQUEST.
THESE INSTRUCTION MANUALS CONTAIN IMPORTANT WARNINGS WHICH MUST BE UNDERSTOOD BEFORE USING THESE FIREARMS.

**STURM, RUGER and Company, Inc.
Southport, Connecticut 06490 U.S.A.**

ALL RUGER FIREARMS ARE DESIGNED AND MANUFACTURED
IN RUGER FACTORIES IN THE UNITED STATES OF AMERICA

FIREARMS SAFETY—YOUR RESPONSIBILITY

SAFETY MUST BE THE FIRST AND CONSTANT CONSIDERATION OF EVERY PERSON WHO HANDLES FIREARMS AND AMMUNITION.

This Instruction Manual is designed to assist you in learning how to use and care for your rifle properly.

Only when you are certain you fully understand the Manual and can properly carry out its instructions should you practice loading, unloading, etc. with live ammunition.

If you have any doubts about your ability to handle or use a particular type of gun safely, then you should seek supervised instruction.

Such personalized instruction is often available from gun dealers, gun clubs or police departments. If none of these sources can help you, write to the National Rifle Association, Washington D.C. 20036. They will assist you.

The person with a gun in his possession has a full-time job. He cannot guess; he cannot forget. He must know how to use his firearm safely. *Do not use any firearm without having a complete understanding of its particular characteristics and safe use.* Remember: There is no such thing as a foolproof gun.

TABLE OF CONTENTS

	Page
General Information and Mechanical Characteristics	3
Ammunition	3
The Safety and its Operation	5
Operation of the Slide Handle	6
To Load and Fire	6
To Unload the Magazine	7
Avoiding Malfunctions ("Jams")	8
To Clear a Malfunction ("Jam")	8
Basic Disassembly (Field Stripping)	9
Removing Slide and Bolt	9
Installing Slide and Bolt	10
Sight Adjustment	10
Care and Cleaning	10
Service and Parts Policy	11
The Basic Rules of Safe Firearms Handling	15
Warranty Information	16

WARNINGS OF GREAT IMPORTANCE ARE FOUND ON THE FOLLOWING PAGES:

Alteration	2	Ejection of Fired Cases	7
Reloaders & Shooters	3	Handling	7
Ammunition	3&4	Lubrication	11
Bore Obstructions	4	Parts Purchasers	12
Loading	4	Malfunctioning Parts	13

Other Cautions and Warnings Appear Throughout the Manual

ALTERATION WARNING

Sturm, Ruger & Company, Inc. will not be responsible for *any* alteration of *any* part of this firearm after it leaves our control, or for the addition or substitution of parts or accessories not manufactured by Sturm, Ruger & Company, Inc. This product was designed to function properly *in its original condition*. Any changes made in this product are specifically contrary to our instructions and we expressly do *not* authorize any changes to be made after manufacture. *Do not jeopardize your safety or the safety of others by making modifications to your firearm.*

FIREARMS ARE DANGEROUS WEAPONS— READ THE INSTRUCTIONS AND WARNINGS IN THIS MANUAL THOROUGHLY AND CAREFULLY BEFORE USING THIS FIREARM

THE RUGER MODEL 44 CARBINE Caliber 44 Magnum

GENERAL INFORMATION AND MECHANICAL CHARACTERISTICS

The Ruger Model 44 is a gas-operated autoloading carbine with a tubular magazine. The action-slide is energized by a short-stroke piston which is driven by a very small portion of propellant gas tapped from the barrel during firing.

The piston slides in a cylinder which is located under the barrel, inside the forend. The bore of the cylinder is connected to the bore of the barrel by a gas porthole which permits a small portion of the propellant gas to enter the cylinder and drive the piston a short distance (approximately $5/16$ ") rearwardly against the forward end of the action slide. By the time this piston stroke has been completed, the bullet has left the muzzle of the gun, pressure in the barrel has fallen to a negligible level and the action-slide has been accelerated to its maximum velocity. The remainder of the slide stroke is completed on momentum and during this stroke, which is toward the rear of the gun, the slide compresses the long coil spring which will return the slide to its battery position. This reciprocation of the slide for each shot actuates the various elements of the action, which accomplishes reloading of the rifle. The breech bolt is the rotating type, having three long locking-lugs at its rearward end.

AMMUNITION

The Ruger Model 44 Carbine is chambered for the 44 Magnum cartridge and no attempt should be made to use any other 44 caliber ammunition. Most of the 44 Magnum loads listed in the catalogs of the leading ammunition manufacturers are suitable for use in the Model 44 Carbine. However, the "Medium Velocity" loading cannot be recommended because it does not always reliably function the mechanism.

Industry Standard loadings with jacketed bullets are preferable to lead bullet loadings because they are generally the most accurate and jacketed bullets are less likely to clog the gas porthole.

WARNING TO RELOADERS AND SHOOTERS

Use only standard flat nose bullets designed for use in tubular magazine firearms. Pointed or round nose bullets can contact the primer of the cartridge ahead in the magazine and cause it to fire during recoil. This will result in severe damage to the firearm and injury to the shooter and bystanders.

Note: Sturm, Ruger & Co. specifically does not recommend the use of reloaded, hand loaded or remanufactured cartridges. See Ammunition Notice on Page 4.

DANGER—AMMUNITION WARNING

Firearms may be damaged, and death or serious injury to the shooter or other persons may result from any condition which contributes to the generation of excessive pressure, or the uncontrolled release of gas, within a firearm. The foregoing adverse conditions can be caused by *bore or chamber obstructions, propellant powder overloads, or by defective, incorrect, or improperly loaded and assembled cartridge components.*

It is extremely dangerous to use a cartridge whose pressure is greater than that developed by cartridges loaded to Industry Standards. Even the strongest firearm can be blown up as a result of excessive pressure.

AMMUNITION (CARTRIDGES) NOTICE

WE SPECIFICALLY DISCLAIM RESPONSIBILITY FOR ANY DAMAGE OR INJURY WHATSOEVER OCCURRING IN CONNECTION WITH, OR AS THE RESULT OF, THE USE IN RUGER FIREARMS OF FAULTY, OR NON-STANDARD, OR "REMANUFACTURED" OR HAND LOADED (RELOADED) AMMUNITION, OR OF CARTRIDGES OTHER THAN THOSE FOR WHICH THE FIREARM WAS ORIGINALLY CHAMBERED.

BORE OBSTRUCTIONS WARNING

Before loading or shooting the rifle, be certain the bore is unobstructed. Firing the rifle with any obstruction in the bore may result in severe damage to the rifle and serious injury to the shooter and persons nearby.

If you suspect the rifle may have excess oil or grease in the bore, or if it may have been exposed to humid conditions which could cause condensation, or to rain or snow which might have entered the bore, inspect the bore to be sure it is clear.

A lodged bullet is a common form of bore obstruction. Therefore the following information deserves careful reading.

1) A bullet may become lodged in the bore if (assuming the trigger has been pulled with a live cartridge in the chamber) the cartridge contains no powder, or the powder fails to ignite, and only the primer charge ignites, resulting in insufficient force to propel the bullet out of the bore.

2) A bullet may become lodged in the bore if, in extracting an unfired cartridge from the chamber, the cartridge case only is removed, thus leaving the bullet lodged in the bore.

The two conditions described above occur most frequently with reloaded ammunition but, however an obstruction occurs, proceed as follows, *with the rifle pointing in a safe direction*:

—Move the safety to the safe position, open the breech and, if present, extract the cartridge case. Remove the remaining rounds from the magazine, and lock the slide in its open position. (See page 7, "To Unload the Magazine.")

—Insert a proper size cleaning rod (without a tip or brush) into the bore from the muzzle and remove the bullet. If the bullet does not readily dislodge, it may be necessary to lightly tap the handle end of the cleaning rod. Do not attempt to remove a lodged bullet using a blank cartridge, or a cartridge from which the bullet has been removed, or by any means other than the use of a cleaning rod. Be certain all loose powder has been removed from the bore and action before inserting the rod.

After removing the obstruction, reinspect the bore to be certain it is free of powder particles or other debris. Clean the mechanism of unburned powder grains.

REMEMBER: Always check the bore for an obstruction if you experience difficulty in chambering a cartridge, experience a failure to extract, have a misfire, or the rifle does not make a normal loud report on firing.

A misfire or unusual report is always a signal to cease firing and immediately examine the bore of the firearm.

LOADING WARNING

Be certain the primer of each cartridge is seated flush with, or below, the surface of the cartridge case base. A primer discharged by the impact of the closing breech mechanism can result in a premature discharge of the cartridge with possible serious injury to the shooter and those nearby. Also, do not attempt to *force* the slide handle to close over a cartridge. If a cartridge does not chamber readily, check the bore and chamber to be certain they are free of obstructions. If they are clear, and the cartridge does not chamber readily, then check the cartridge to be certain it is the proper caliber, and of correct dimensions, for the rifle.

THE SAFETY AND ITS OPERATION

The Model 44 Carbine has a cross-button safety which is located in the forward portion of the trigger guard. (Figure 1). The safety can be operated (moved from one position to the other) *only when the hammer is cocked*.

The safety should always be in the "on" (safe) position except when the shooter is actually firing the gun. The safety must be moved to the "on" position when the shooter ceases firing.

The safety is "on" when it protrudes fully from the *right side** (the slide handle side) of the trigger guard assembly, as shown in Figure 1. In this position the sear is blocked, and the gun cannot be fired from a normal pull on the trigger.

The safety is "off" when it protrudes fully from the left side of the trigger guard assembly, as shown in Figure 2. When the safety is off, the red band shows on the safety button. **CAUTION:** Do not totally rely on the appearance or recognition of the red band to indicate that the safety is on. In poor light or if dirt is present, the red band may not be visible. Know without fail that the safety is "off" (fire) when the safety protrudes from the left side of the trigger guard assembly. When the safety is "off" and the trigger is pulled, the rifle will fire.

When the safety is moved to either the "on" or "off" position, a distinct "click" should be heard. Also, the safety should, to a degree, resist being moved out of either position. The safety is held in its "on" or "off" position only by a plunger that is

(Continued on next page.)

* Reference to the "right" side of the rifle assumes that the muzzle of the firearm is pointing away from the shooter which is the position that the shooter assumes when he shoulders the firearm to shoot.

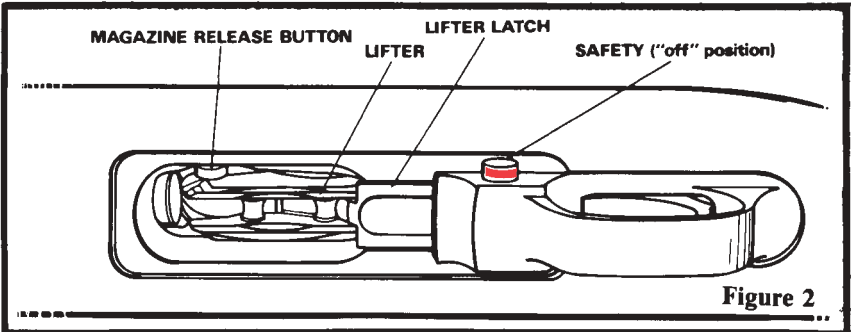
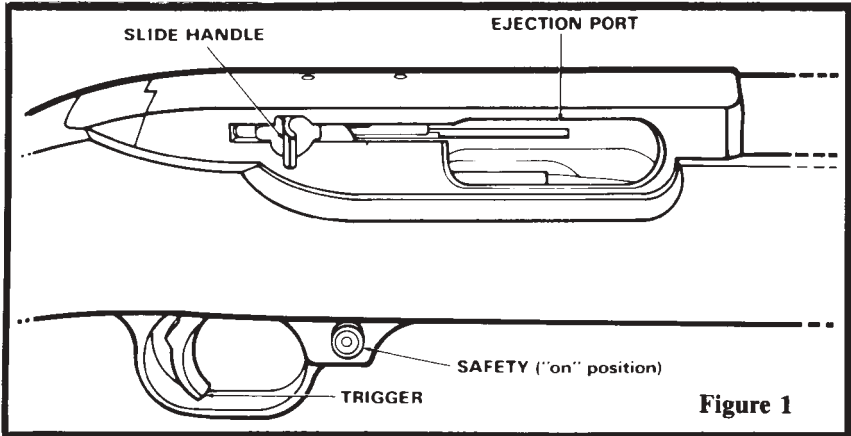

under spring tension. Therefore, the shooter should frequently check the position of the safety to be certain the safety has not been inadvertently moved. If the safety seems to move too easily, or if the click is not heard when the safety is moved, the rifle should be discontinued from use and returned to the Southport Service Dept. for repair. **WARNING: THE USER SHOULD NEVER DEPEND ON A SAFETY MECHANISM OR ANY OTHER MECHANICAL DEVICE TO JUSTIFY CARELESS HANDLING OR PERMITTING THE RIFLE TO POINT IN AN UNSAFE DIRECTION.**

OPERATION OF THE SLIDE HANDLE

To cock the hammer, grasp the slide handle between thumb and forefinger and draw fully to the rear. If there are no cartridges in the magazine, the slide will remain locked in its rearward position. *Immediately* push the safety to the “on” position. The safety should always be pushed to “on” (safe) just as soon as the slide is fully rearward.

To release the slide, depress the lifter latch (see Figure 2) with the thumb or index finger. This will allow the slide—to which the bolt is attached—to instantly fly forward with considerable force. So, keep fingers out of the way.

If there is a cartridge in the magazine when the slide handle is drawn to the rear, the slide will *not* lock in its rearward position, but rather, when released, will move forward and pick up a cartridge and chamber it. As always, when there is a cartridge in the chamber, the safety should be “on”.

TO LOAD AND FIRE

(Rifle Must be Pointing in a Safe Direction)

1. Draw the slide handle to the rear until it is latched in its rearward position.
2. Move the safety to the “on” position.
3. Drop a cartridge into the ejection port, bullet end towards the muzzle. Press the lifter latch. This will release the slide (which is attached to the bolt) and the bolt will chamber the cartridge and lock. (See **LOADING NOTE** below.)
4. Holding the rifle upside down, and using a cartridge (as illustrated in Figure 3), depress the lifter latch and then the lifter in one smooth motion. As the lifter is depressed the rear end of the magazine can be seen. Using the thumb of the right hand, push the cartridge fully into the magazine until the base of the cartridge is held by the inside end of the magazine release button. A maximum of four cartridges may be so loaded into the magazine. *Remember there is a cartridge in the chamber!*

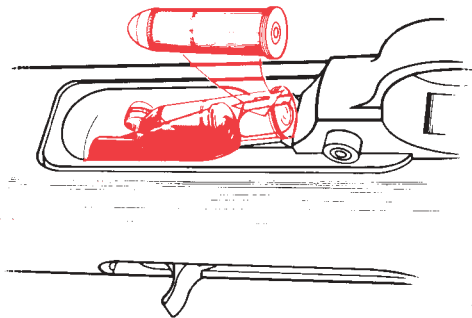

Figure 3

5. The gun is now fully loaded. When the safety is pushed to the “off” position the gun is ready to be fired by a pull on trigger. **DO NOT TOUCH THE TRIGGER UNTIL YOU ARE ACTUALLY READY TO FIRE.**

6. Each time the trigger is pulled a cartridge is fired and then, automatically, an empty cartridge case is extracted and ejected, and a new cartridge is chambered. This cycle continues until all cartridges have been fired. After the last shot has been fired the slide will remain locked open. Move the safety to the “on” position just as soon as the firing sequence is completed.

LOADING NOTE: Step 3—loading a cartridge directly into the chamber—can be eliminated if it is desired to load only the magazine. If only the magazine is to be loaded, the slide should be released so that it is fully forward before a cartridge is

loaded into the magazine. If an attempt is made to load the magazine while the slide is in its rearward position, the slide will slam forward as soon as the cartridge is pressed against the lifter latch.

EJECTION OF FIRED CASES WARNING

When firing the Model 44 Carbine be sure that bystanders are well clear of the shooter and standing a safe distance to the rear. Empty cartridge cases are ejected from the carbine to the right with some velocity and could cause injury to any person who is standing too closely alongside the shooter. Left-handed shooters should be particularly cautious concerning ejected cartridge cases and should wear shooting glasses to avoid the possibility of injury from ejected cartridge cases and particles of powder. All shooters should wear suitable shooting glasses when firing the Carbine. The Model 44 Carbine *should* be fired from the right shoulder.

TO UNLOAD THE MAGAZINE

Be certain the rifle is pointing in a safe direction.

1) Put the safety "on". (If the safety cannot be put "on" it is because the hammer is not cocked. There is no need to cock the gun in this situation because retracting the slide to cock the gun would automatically start the cycle to bring a cartridge from the magazine into the chamber. That is not what is wanted.)

2) Turn the rifle upside down (the position as shown in Figure 3) and press the magazine release button inward with the thumb. One at a time the cartridges can then be removed from the magazine. **WARNING:** When emptying the magazine be certain every cartridge is removed. Do not trust to 'feel'. Visually inspect and be certain the magazine follower is visible. **WARNING: EMPTYING THE MAGAZINE DOES NOT PREVENT THE RIFLE FROM BEING FIRED. CHECK THE CHAMBER AFTER EMPTYING THE MAGAZINE TO BE CERTAIN THE CHAMBER IS EMPTY.**

HANDLING WARNING

Do not load the rifle until you are ready to use it, and unload it *immediately* when you have completed shooting.

Do not chamber a cartridge until you are in the immediate area where you plan to shoot. Put the safety in the safe position before chambering a cartridge, and never carry the rifle loaded with the safety in the fire position.

The rifle should be carried and handled so it will not be dropped or struck. With the safety off, the rifle is in the ready-to-fire mode. Therefore, as in any firearm, any blow or jar which is of sufficient force to actuate components of the firing mechanism may cause a chambered cartridge to discharge. Such a discharge can occur with or without the trigger being directly struck or touched.

Never rest a loaded rifle against any object (wall, fence, vehicle, tree, etc.) because there is always the possibility that the rifle will be jarred or slide from its position and fall with sufficient force to discharge.

Never store a firearm in such a manner that it may be pulled from a shelf or 'hidden place' as some other item is moved.

The shooter should always be alert to the possibility of accidental discharge regardless of the position of the safety. The only safe rifle is one in which the bolt is open and the magazine and chamber are empty.

NOTE: The Model 44 Carbine is like the M1 Garand and many other types of semi-automatic, gas operated rifles in that the hammer can fall if the trigger is pulled when the bolt is partially retracted. It is important for the shooter to realize that the firing pin *cannot* contact the cartridge until the bolt is safely locked.

AVOIDING MALFUNCTIONS (“JAMS”)

It is well known that autoloading firearms of all makes and types are susceptible to occasional malfunctioning due to a cartridge not feeding from the magazine to the chamber, or due to a cartridge (or fired case) not being extracted and ejected as it should be.

To minimize the possibility of such occurrences the gun user should:

—Use ammunition of the correct caliber and type which is loaded to Industry Specifications. Avoid reloads, remanufactured cartridges, and cartridges that are deformed.

—Clean and lubricate the gun in accordance with the instructions in this Manual.

—Learn to smoothly function the slide and to load and empty the chamber and magazine.

—If the mechanism shows signs of not functioning correctly, or if a part is damaged or broken—don't use the gun. Have it inspected, and repaired.

Perhaps the most common occasion of a cartridge becoming 'jammed' is when the gun user is attempting to remove a *live* (unfired) round from the chamber. To minimize the possibility of a cartridge falling 'back into' the mechanism during the cartridge extraction-ejection operation, hold the Carbine with the ejection port toward the ground, and position the palm of the left hand to catch the cartridge as it is ejected. Use the right thumb and forefinger to smartly retract the slide handle. This brisk stroke of the slide, plus the weight of the cartridge, should cause it to readily fall into the palm.

The slide should be pulled fully to the rear during the cartridge extraction cycling so that the slide locks in place at the end of the stroke. Locking the slide prevents it from moving forward and possibly jamming the cartridge if it was not thrown clear of the receiver. NOTE: The slide *cannot* be locked in its rearward position when there are cartridges—even just one—in the magazine.

If the user finds it difficult to handle the carbine so the ejected cartridge can be caught in the palm of the hand, then simply position a cloth or similar soft object beneath the ejection port so the cartridge will fall on it. A live cartridge should never be ejected, or dropped onto a hard surface that might forcibly contact the primer and fire the cartridge.

TO CLEAR A MALFUNCTION (“JAM”)

If a jam occurs, immediately put the safety “on” and be certain the muzzle of the carbine is at all times pointing in a safe direction.

Then study the situation to determine the nature of the jam, and how best to clear it.

—If a cartridge or shell is jammed between the bolt and the receiver, depress the lifter latch and then the lifter and remove all cartridges from the magazine. Then retract the slide handle fully (to locked position) and remove the jammed cartridge or case.

—If a cartridge has become wedged in a vertical position between the lifter and the inside-top of the receiver, be certain the slide is fully rearward and *locked* in position. Then use a piece of wooden dowel (with a tapered or pointed end) to rotate the cartridge to the horizontal position so it can be shaken out of the receiver.

—When attempting to free a jammed cartridge, do not use any type of tool that is likely to act as a 'firing pin' and discharge the cartridge should the tool impact on the primer.

—If a cartridge or case becomes wedged in such a way that it cannot be removed by the user, *and* at the same time the lifter cannot be depressed to remove cartridges from the magazine, then the Carbine must be turned over to a qualified gunsmith* for repair.

—After clearing a jam, inspect the gun mechanism to determine if dirt or debris might be the cause of the problem. Excess lubricant or grease can cause cartridges to feed sluggishly. An accumulation of grease or dirt in the magazine tube can contribute to cartridge feeding problems.

—After clearing a jam, inspect all cartridges that have been removed from the gun. Safely dispose of any cartridges which are dented or nicked or have bullets that are

* For regular repairs we recommend that Ruger guns be returned to the factory. However, if a gun has cartridges in it which cannot be removed, then it is a violation of Federal Regulations to ship that loaded gun whether it be by U.S. Mail or by common carrier.

loose or improperly positioned in the cartridge case.

— If it appears that the gun and magazine are not at fault and that the jam was caused by the type of cartridge being used, then try another type.

— If the above procedures do not result in a smooth and reliable feeding firearm, don't use the gun until it feeds cartridges smoothly and reliably. The Carbine can be returned directly to our Southport Service Department for repair. See the Service and Parts Policy section of this manual for packing and shipping information.

Another precaution: Form the habit of examining fired cartridge cases from time to time. If fired cases have bulged heads or frequently show splits on any part of the case, the rifle should be returned to the factory for inspection.

BASIC DISASSEMBLY (Field Stripping)

Field stripping includes only the removal of the barrel-receiver and trigger guard assemblies from the stock and is accomplished as described below:

1. Be certain the magazine and chamber are emptied of cartridges. The rear sight leaf should be down.

2. Draw slide to the rear until it is latched in its rearward position.

3. Loosen barrel band screw and remove the barrel band.

4. Lift the barrel away from the forearm tip (of the stock) until the tenon at the rear end of the receiver is clear of the recoil block in the stock.

TO REASSEMBLE, proceed in reverse order of above. When installing the receiver in the stock, make certain the tenon is correctly positioned, *and that the slide is locked in its rearward position.*

REMOVING SLIDE AND BOLT

CAUTION: Before attempting the following disassembly/reassembly procedure it is advisable to study the exploded view parts drawing in the rear of this manual so as to have a clear idea of which parts are being referred to.

A 1/8" drift punch, a screwdriver with a blade to fit the ejector screw and a small plastic hammer are the required basic tools. A pair of work gloves may be useful to some persons because the slide spring resists easy compression.

The barrel-receiver assembly, with trigger guard assembly attached, having been removed from the stock (as described above), proceed as follows:

1. Release the slide and carefully guide it to its forward position.

2. Drift out the receiver cross pin (C-5) and move the trigger guard assembly approximately 1/8" rearward to disengage it completely from the receiver. **CAUTION:** At this point the slide spring can suddenly expand. Remove the spring from the magazine tube, then remove the tube.

3. Press down on the slide (towards the top of the receiver) and move it to the rear at least 1/4" so the slide handle (C-48-B) can be removed from the slide. It may be necessary to tap the slide handle with a screwdriver to free it.

4. With the slide handle removed, the slide (C-47) can be lifted out of the receiver.

NOTE: When the magazine assembly and slide have been removed from the gun, the piston (C-58) is free to fall clear of the cylinder. Care must be taken to avoid loss of the piston.

5. To remove the bolt, the ejector (C-8) must be pressed out of the way of the bolt or it must be removed by first removing the ejector screw (C-9). To be disassembled from the receiver, the bolt must be positioned about half way between its forward and rear positions, as shown in Figure 4. Then, with the bolt in this position and the ejector pressed out of its way (or removed), the bolt may be rolled toward the ejection port side of the receiver and lifted clear.

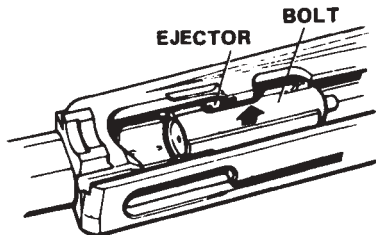

Figure 4

INSTALLING SLIDE AND BOLT

1. Install bolt in the receiver, move it forward and rotate it into its locked position. If the ejector was removed, it should now be installed.
 2. Make certain the gas piston (C-58) and piston block plug (C-60) are in place in the cylinder.
 3. Position the slide (without the handle in place) on the receiver.
 4. Position the magazine within the slide. Be certain that the slot in the forward end of the magazine plug (C-73) is fitted to the lug on the cylinder block with the heavy section of the plug next to the barrel.
 5. Move the slide forward to the point where the slide handle can be pushed into its seat in the slide.
 6. Slip the slide spring over the magazine tube and compress it until the forward end of the tube can be snapped into its seat in the forward end of the receiver. With the same motion, the rear end of the slide should be brought to its final position in the receiver with the slide stud engaging the cam area of the bolt. NOTE: During this operation the very strong slide spring (recoil spring) must be controlled at all times. This operation calls for patience, an understanding of what is to be done, and reasonably strong hands. The work gloves—especially on the hand compressing the spring—can be useful.
 7. With the slide and spring properly positioned, the trigger guard assembly is laid in place and the cross pin installed to secure the trigger guard assembly to the receiver.
 8. Draw the slide back and then release it. Repeat this cycling a few times to be sure all components are correctly assembled.
- NOTE: Routine care and maintenance of the Model 44 Carbine does not require the removal of the slide, bolt, ejector and trigger guard assembly.

SIGHT ADJUSTMENT

The folding leaf rear sight is adjustable for elevation. The slide must be moved one graduation to change the point of impact by approximately one inch at 50 yards. Shooting to determine the slide setting should be done from a bench rest and over a measured distance. Use only a small screwdriver with a blade tip that *exactly* fits the screw-head. Loosen the screws only slightly so the slide doesn't move too freely. Move the slide in the direction you want the point of impact of the bullet to move. When the slide is positioned at the desired height, carefully tighten both screws.

Lateral (windage) adjustment is made by 'drifting' the sight base in its slot. Place a short brass rod against the sight *base (and only the base)* and tap the sight in the direction you wish to move the point of impact. Before moving the sight, pencil mark an index line on the sight base and rib so that sight movement can be detected.



SUGGESTED SIGHT PICTURE

Top of front sight even with top of rear sight *slide*. Front sight centered in notch of rear sight slide. Target bullseye centered on top of front sight.

WARNING: Do not remove the scope base filler screws—there are two in the receiver and two in the barrel—unless a base or sight is to be mounted using properly fitting screws. Do not deepen or alter the two screw holes that are in the barrel.

CARE AND CLEANING

Before cleaning, be certain the rifle and its magazine contain no cartridges.

A firearm must be free of rust, dirt, grease and firing residues to function safely and reliably. Periodic maintenance, which includes inspection of components to determine if they are in proper working order, is absolutely essential.

Basic cleaning equipment includes: A correct size Cleaning Rod equipped with bore brushes (fiber and brass) and a tip in which a cloth patch can be inserted, Patches, Powder Solvent, Lubricant, Small lint-free Cloths and a Toothbrush.

Some hints for effective use of the equipment: use correct size brushes and patches; if they are too small they don't do the job; if too large they bind in the bore. Insert rod from the chamber end and push firmly so the patch or brush emerges from the muzzle. Don't reverse the rod when a brush or patch is being used—it may bind. Don't use patches or brushes dripping with solvent or oil. Wet them, and squeeze out excess before using. Use rod and brushes with care so as not to damage gun.

1. To clean the rifle thoroughly, disassemble to the extent described above, taking care to put pins, screws and similar easily mislaid and 'rolling' components in a tray.

2. Push-pull a solvent-wetted patch through the bore several times. Next, using a solvent-wetted brush, run it the full length of the bore as many times as is necessary to completely remove all foreign matter from the bore and chamber. Dry the bore with clean patches and examine it. If bore remains fouled, repeat the brushing *because bullet jacket fouling can greatly reduce accuracy and grease can interfere with proper chambering of the cartridge*. Complete the cleaning by dry-patch wiping of bore and chamber.

3. Use a clean, solvent-wetted patch to remove firing residue and dirt from all components and 'reachable' surfaces inside the receiver. Use the solvent-wetted tooth-brush to dislodge caked dirt from components and from surfaces inside the receiver that can't be reached with a patch. Now use cleaning patches or the cloth to dry off the solvent.

4. Wipe all surfaces—internal and external—with oil-wetted patch or cloth that will deposit a very light and sparing coat of oil. Oil and similar preparations 'collect' dirt particles which can interfere with reliable functioning of the rifle. Therefore, use these preparations very sparingly.

The most significant lubrication points are as follows:

Rear end of slide where it rides on its bearing surfaces in the receiver and trigger guard housing.

Forward end of slide where it rides on the magazine tube.

The locking surfaces on both bolt and receiver and the surfaces of the bolt rotating cam.

Stud on the inside rear end of the slide, which engages the bolt rotating cam.

Various pivot points in the trigger guard housing, such as the trigger pivot, hammer pivot, lifter pivot, safety, etc.

Do not flood the bore with oil—it is not desirable to cause an accumulation of oil in the gas cylinder. The gas piston and the gas plug are made of stainless steel. They will not corrode readily, but an occasional drop of oil on the piston will protect the gas cylinder bore against rust.

5. Reassemble the rifle and carefully wipe all solvent, lubricating and preservative preparations from the stock and forearm wood.

6. If the rifle is to be stored for an extended period, rewipe all external surfaces with the cloth containing the oil or preservative.

CAUTION: Do not store the rifle in a leather case or scabbard. Leather attracts moisture, even though it may appear to be dry.

WARNING: Never store a firearm in such a manner that it may unintentionally be dislodged. *A firearm should be stored securely and unloaded.*

LUBRICATION WARNING

Firing a rifle with oil, grease, or any other material even partially obstructing the bore may result in damage to the rifle and injury to the shooter and those nearby.

Do *not* spray or apply lubricants directly on ammunition. If the powder charge of a cartridge is affected by the lubricant, it may not be ignited, but the energy from the primer may be sufficient to push the bullet into the bore where it may become lodged. Firing a subsequent bullet into the obstructed bore may damage the rifle and cause injury to the shooter and those nearby. *Use lubricants properly*. You are responsible for the proper care and maintenance of your firearm.

SERVICE AND PARTS POLICY

If you have any question with regard to the performance of your Carbine, please write to our Southport, Connecticut Service Department, fully describing all circumstances and conditions involved.

If you should return your Carbine to the factory for repair, or order parts for it, please comply with the following suggestions for prompt service:

SHIPPING FIREARMS FOR REPAIR:

Ruger Model 44 Carbines returned to the factory for repair should be sent to: Sturm, Ruger & Co., Inc., Service Department, Southport, CT 06490

Guns should be sent prepaid. *We will not accept collect shipments.*

The Federal Gun Control Act, as well as the laws of most States and localities, does not prohibit an individual (who is not otherwise barred from purchasing or possessing a firearm) from shipping a firearm directly to the manufacturer for repair. However, before you ship your rifle to us, be certain that your State or locality does not have a law or regulation which will prohibit you from receiving the rifle from us after it has been repaired. If such receiving is prohibited, then please have a Federally Licensed firearms dealer ship the gun to us. If your rifle is sent to us by a dealer, it will be returned to him after being repaired. If a handgun (pistol or revolver) is shipped by an individual who does not hold a Federal Firearms License, it *must* be shipped via UPS. Persons who do not hold a Federal Firearms License are prohibited by Federal law from shipping a handgun by Mail. Handguns mailed in violation of the law are impounded by the Post Office.

Please do *not* include rifle case, sling, telescopic sight, or custom accessories with a firearm being shipped to the factory for service. Rifles and shotguns may be shipped via Parcel Post. Always insure your shipment.

Enclose a letter which includes your name, address, telephone number, and serial number and model of the firearm. Describe in detail the trouble you have experienced with your firearm, or the work you wish to have done. Merely stating that the firearm 'needs repair' is inadequate information.

Work performed will bear a net minimum labor charge of \$5.00. The charge for rebluing the Model 44 Carbine is \$15.00, which includes labor. NOTE: When the Carbine is reblued, the trigger guard is *not* reanodized. We do not anodize Ruger parts on a repair basis.

WARNING: Before shipping any firearm, be absolutely certain that it and its' magazine are unloaded. Do not ship cartridges with a firearm.

ORDERING PARTS:

All parts orders should be sent to:

Sturm, Ruger & Co., Inc., Service Department, Southport, CT 06490

Payment must accompany order. Minimum parts order is \$1.00.

Order parts by Part Number and Part Name and *include the entire serial number of the firearm* for which the parts are being ordered.

*Parts designated by an asterisk *must* be factory fitted. The price shown for these parts does not include the *minimum* net labor charge of \$5.00. All parts in the Parts List marked with an asterisk are factory replaced *on an exchange basis only*. We will not return the replaced parts.

Because it is a serial numbered component, the Carbine Barrel-Receiver Assembly is defined as a "firearm" by Federal law and is not sold as a separate component. The Barrel-Receiver of the Model 44 Carbine is an integrated assembly, therefore, the barrel alone is not available as a separate component part.

WARNING TO PARTS PURCHASERS

It is the purchaser's responsibility to be absolutely certain that any parts ordered from the factory are correctly fitted and installed. Firearms are complicated mechanisms and IMPROPER FITTING OF PARTS MAY RESULT IN A DANGEROUS MALFUNCTION, DAMAGE TO THE FIREARM, AND INJURY TO THE SHOOTER AND OTHER PERSONS. The purchaser and installer of parts must accept full responsibility for the correct adjustment and functioning of the pistol after such installation.

Firearms users are cautioned that a gun containing modified, broken, malfunctioning, or badly worn parts should not be fired!

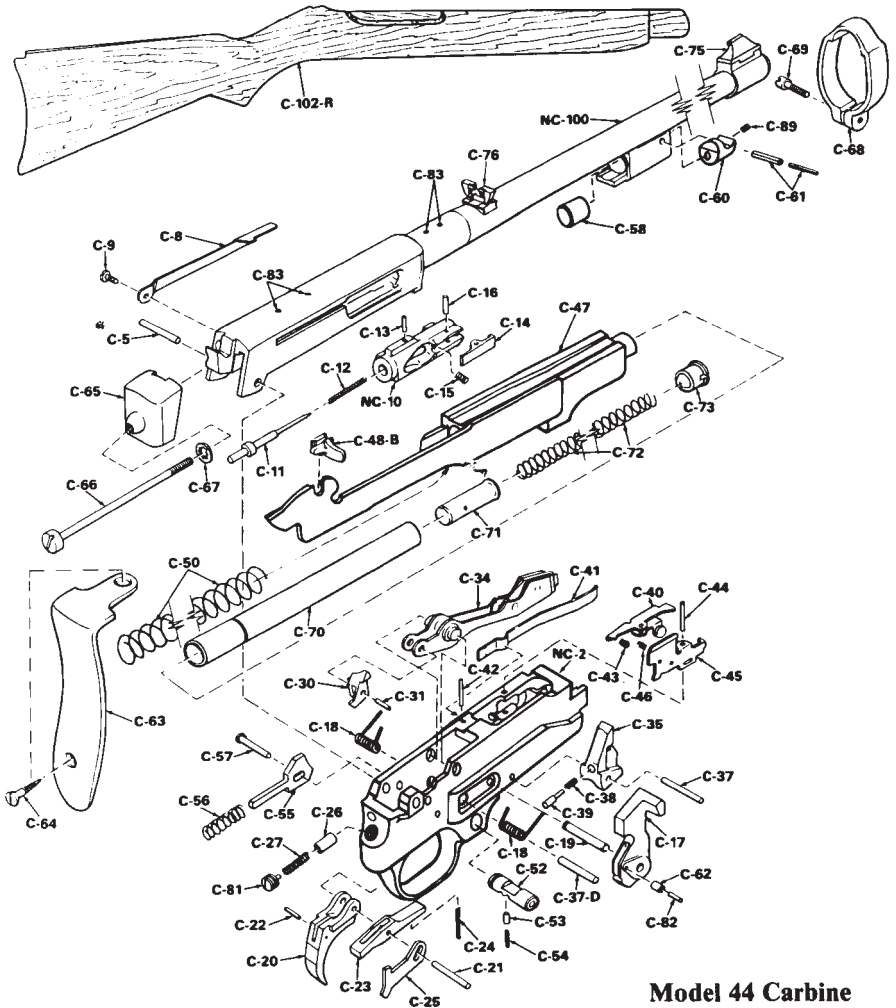

Model 44 Carbine

PARTS LIST AND SUGGESTED RETAIL PRICES

Part No.	Part Name	Price
NC-100	Barrel-Receiver Assembly (Not sold separately)	\$144.50
C-68	Barrel Band Assembly (Carbine Stock)	3.75
C-69	Barrel Band Screw	.50
* NC-10	Bolt (Only)	28.25
* NC10A	Bolt (Assembly)	43.25
C-63	Butt Plate, Carbine	.75
C-64	Butt Plate Screw	.50
C-40	Cartridge Stop	.50
C-41	Cartridge Stop Flat Spring	.50
C-42	Cartridge Stop Flat Spring Retaining Pin	.50
C-43	Cartridge Stop Coil Spring	.50
C-44	Cartridge Stop Pivot Pin	.50

C-25	Disconnecter	.50
C-26	Disconnecter Plunger	.50
C-27	Disconnecter Plunger Spring	.50
C-81	Disconnecter Plunger Spring Screw	.50
C-8	Ejector	1.00
C-9	Ejector Screw	.50
C-14	Extractor	1.00
C-15	Extractor Spring	.50
C-16	Extractor Pivot Pin	.50
C-45	Flapper	1.50
C-46	Flapper Spring	.50
C-11	Firing Pin	3.50
C-12	Firing Pin Retaining Spring	.50
C-13	Firing Pin Retaining Pin	.50
C-75	Front Sight	6.50
C-17	Hammer, including Roller	6.50
C-18	Hammer Springs (Right and Left)	.50
C-37-D	Hammer Spring Retaining Pin	.50
C-19	Hammer Pivot Pin	.50
C-34	Lifter Assembly	12.50
C-30	Lifter Dog	6.50
C-31	Lifter Dog Pivot Pin	.50
C-35	Lifter Latch	4.75
C-37	Lifter Latch Pivot Pin	.50
C-38	Lifter Latch Spring	.50
C-39	Lifter Latch Plunger	.50
C-55	Lifter Cam	.75
C-56	Lifter Cam Spring	.50
C-57	Lifter Cam Pin	.50
C-103	Magazine Assembly, Complete	8.00
C-107M	Medallion, Pistol Grip	.50
C-58	Piston	1.25
C-60	Piston Block Plug	1.50
C-61	Piston Block Plug Retaining Pin (2)	.50
C-89	Piston Plug Set Screw	.50
C-5	Receiver Cross Pin	.50
C-76	Rear Sight	4.25
C-76R	Rear Sight, Receiver (Williams) (Fits Deluxe Model only.)	12.50
C-65	Recoil Block	6.25
C-66	Recoil Block Bolt	.50
C-67	Recoil Block Bolt Washer	.50
C-52	Safety	1.00
C-53	Safety Detent Plunger	.50
C-54	Safety Detent Plunger Spring	.50
C-83	Scope Base Hole Filler Screw	.50
C-23	Sear	4.50
C-24	Sear Spring	.50
C-47	Slide Assembly	28.75
C-48-B	Slide Handle	4.75
C-50	Slide Spring	.50
C-77	Sling Swivel—Front, Carbine	1.50
C-78	Sling Swivel—Rear (for all stocks)	1.50
B-92	Sling Swivel Base (Sporter only)	2.25
B-93	Sling Swivel Base Screws (each)	.50
C-102R	Stock Assembly, Carbine, Complete	74.75
* NC-101	Trigger Guard Assembly, Complete	95.50
* NC-2	Trigger Guard Only	31.25
C-20	Trigger (includes cross pin C-22)	4.25
C-21	Trigger Pivot Pin	.50

* Must be fitted at factory. Net minimum labor charge is \$5.00.

Design, specifications and prices subject to change without notice.

THE BASIC RULES OF SAFE FIREARMS HANDLING

We believe that Americans have a right to purchase and use firearms for lawful purposes. The private ownership of firearms in America is traditional, but that ownership imposes the *responsibility* on the gun owner to use his firearms in a way which will ensure his own safety and that of others. When firearms are used in a safe and responsible manner, they are a great source of pleasure and satisfaction, and represent a fundamental part of our personal liberty.

Firearms do not cause accidents! Firearms accidents are almost always found to have been the result of carelessness, or ignorance on the part of the shooter of the basic rules of safe gun handling.

The following rules must be observed by gun users at all times. Safe gun handling is not just desirable, it is absolutely essential to the continuation of gun ownership and sport shooting as we know it today.

1. LEARN THE MECHANICAL AND HANDLING CHARACTERISTICS OF THE FIREARM YOU ARE USING. Not all firearms are the same. The method of carrying and handling firearms varies in accordance with the mechanical provisions for avoiding accidental discharge and the various proper procedures for loading and unloading. No person should handle any firearm without *first* having thoroughly familiarized himself with the particular type of firearm he is using, and with safe gun handling in general.

2. ALWAYS KEEP THE MUZZLE POINTED IN A SAFE DIRECTION. Be sure of the bullet stop behind your target, even when dry-firing. Never let the muzzle of a firearm point at any part of your body or at another person. This is particularly important when loading or unloading a firearm. In the event of an accidental discharge, no injury can occur as long as the muzzle is pointing in a safe direction. A safe direction means a direction which will not permit a discharged bullet to strike a person, or to strike an object from which the bullet may ricochet. A safe direction must take into account the fact that a bullet may penetrate a wall, ceiling, floor, window, etc., and strike a person or damage property. Make it a habit to know exactly where the muzzle of your gun is pointing whenever you handle it, and be sure that you are always in control of the direction in which the muzzle is pointing, even if you fall or stumble.

3. FIREARMS SHOULD BE UNLOADED WHEN NOT IN USE. Firearms should be loaded only when you are in the field or on the target range or shooting area, ready to shoot. Firearms and ammunition should be securely locked in racks or cabinets when not in use. Ammunition should be safely stored *separate* from firearms. Store your firearms out of sight of visitors and children. It is the gun owner's *responsibility* to be certain that children and persons unfamiliar with firearms cannot gain access to firearms or ammunition.

4. BE SURE THE BARREL IS CLEAR OF OBSTRUCTIONS BEFORE SHOOTING. Even a bit of mud, snow or excess lubricating oil or grease in the bore may cause the barrel to bulge, or even burst on firing, and can cause injury to the shooter and bystanders. Be sure that you are using ammunition of the proper caliber and loading for the gun you are using. If the report or recoil on firing seems weak, or doesn't seem quite right, **CEASE FIRING IMMEDIATELY** and check to be sure that no obstruction has become lodged in the barrel.

5. BE SURE OF YOUR TARGET BEFORE YOU SHOOT. Don't shoot unless you know exactly where your bullet is going to strike. Be sure of the bullet stop behind your target, even when dry-firing with an unloaded gun. If you are in the field hunting, do not fire at a movement or noise. Take the time to be *absolutely certain* of your target before you pull the trigger.

6. WEAR SHOOTING GLASSES AND HEARING PROTECTORS WHEN YOU SHOOT. All shooters should wear protective shooting glasses and some form of hearing protectors when shooting. Exposure to shooting noise can damage hearing, and adequate vision protection when shooting is essential.

7. NEVER CLIMB A TREE OR FENCE WITH A LOADED FIREARM. Put the firearm down carefully before climbing a fence, and *unload* it before climbing or descending a tree or jumping over a ditch or other obstruction. Never pull or push a loaded firearm toward yourself or another person. When in doubt, unload your gun!

8. DON'T SHOOT AT A HARD SURFACE, OR AT WATER. Bullets can glance off many surfaces like rocks or the surface of water and travel in unpredictable directions with considerable velocity.

9. NEVER TRANSPORT A LOADED FIREARM. Firearms should always be unloaded before being placed in a vehicle. A suitable carrying case or scabbard should be used to carry a firearm to and from the shooting area.

10. AVOID ALCOHOLIC BEVERAGES WHEN SHOOTING. Don't drink until the day's shooting is over. Handling firearms while under the influence of alcohol in any form constitutes a criminal disregard for the safety of others.

WHY NO WARRANTY CARD HAS BEEN PACKED WITH THIS NEW RUGER FIREARM

The Magnuson-Moss Act (Public Law 93-637) does not require any seller or manufacturer of a consumer product to give a written warranty. It does provide that if a written warranty is given, it must be designated as "limited" or as "full" and sets minimum standards for a "full" warranty.

Sturm, Ruger & Company, Inc. has elected not to provide any written warranty either "limited" or "full", rather than to attempt to comply with the provisions of the Magnuson-Moss Act and the regulations issued thereunder.

There are certain implied warranties under state law with respect to sales of consumer goods. As the extent and interpretation of these implied warranties varies from state to state, you should refer to your state statutes.

Sturm, Ruger & Company wishes to assure its customers of its continued interest in providing service to owners of Ruger firearms.



**STURM, RUGER and Company, Inc.
Southport, Connecticut 06490 U.S.A.**

ALL RUGER FIREARMS ARE DESIGNED AND MANUFACTURED
IN RUGER FACTORIES IN THE UNITED STATES OF AMERICA